

Porównanie z modelem CAD

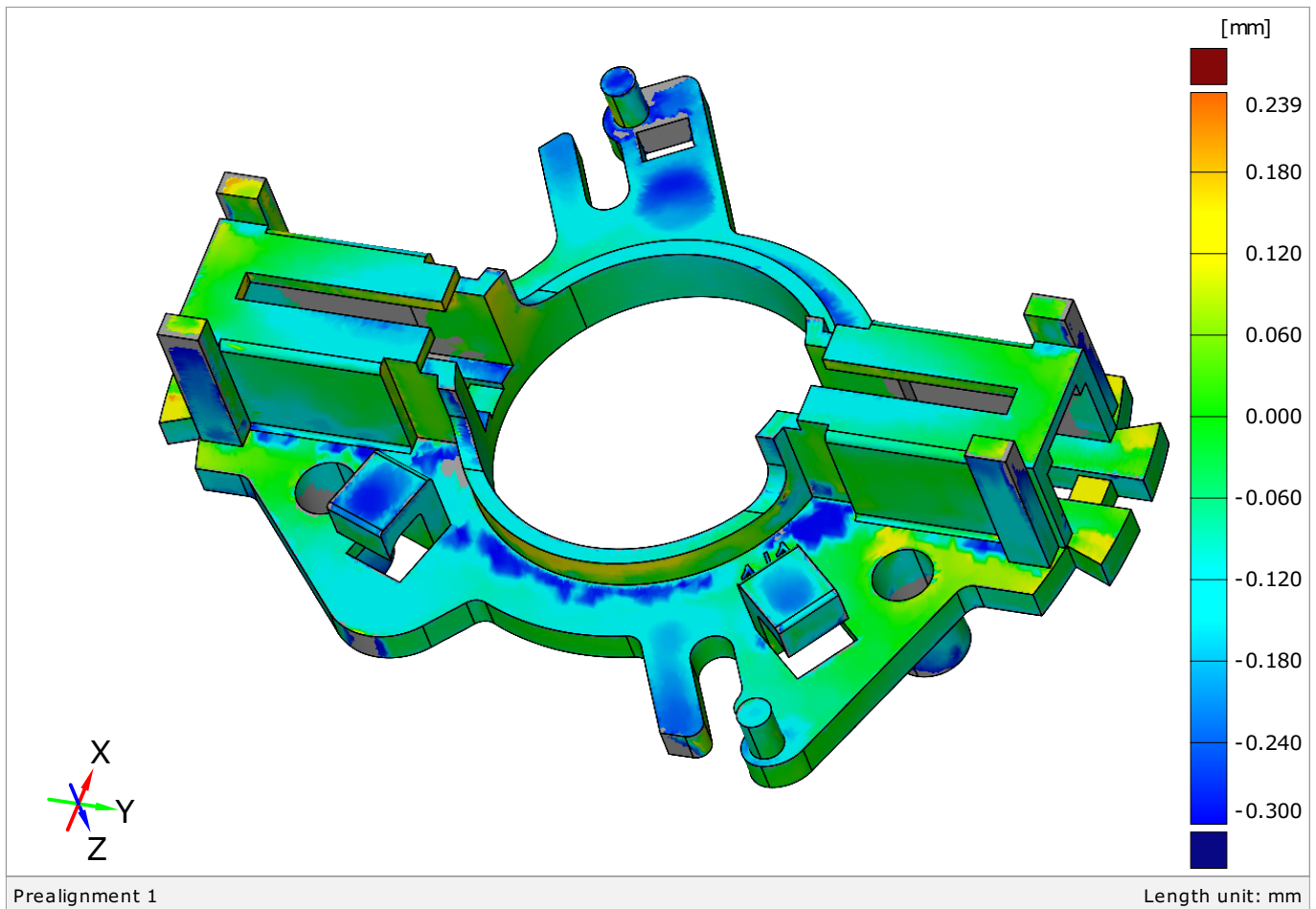

Inspector:

Company: Plast-Zem

Department:

Location: Glogow

Date: 9/26/12

Project:

Part:

Part no.:

Version:

Charge no.:

System:

Pomiary

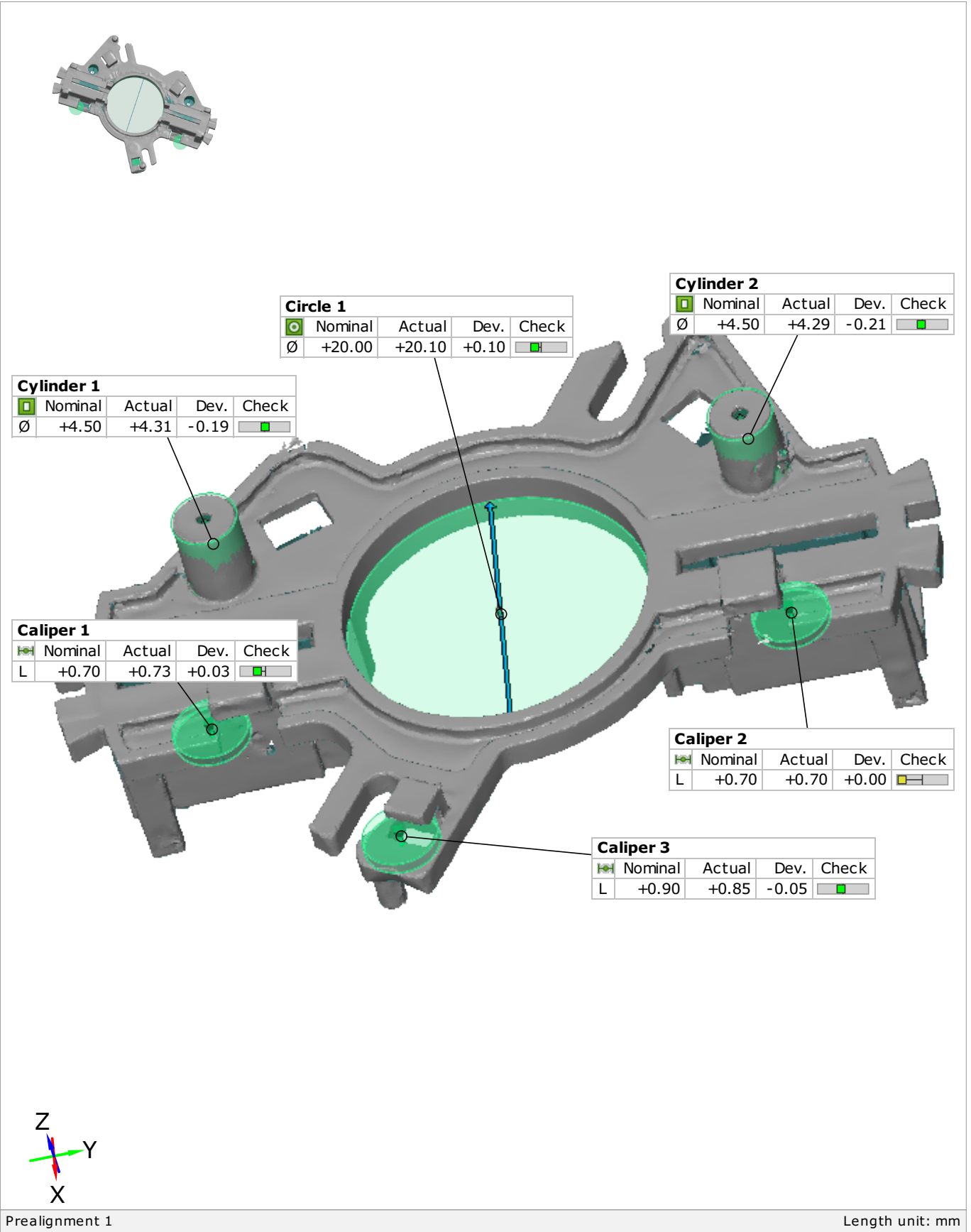

Wyniki

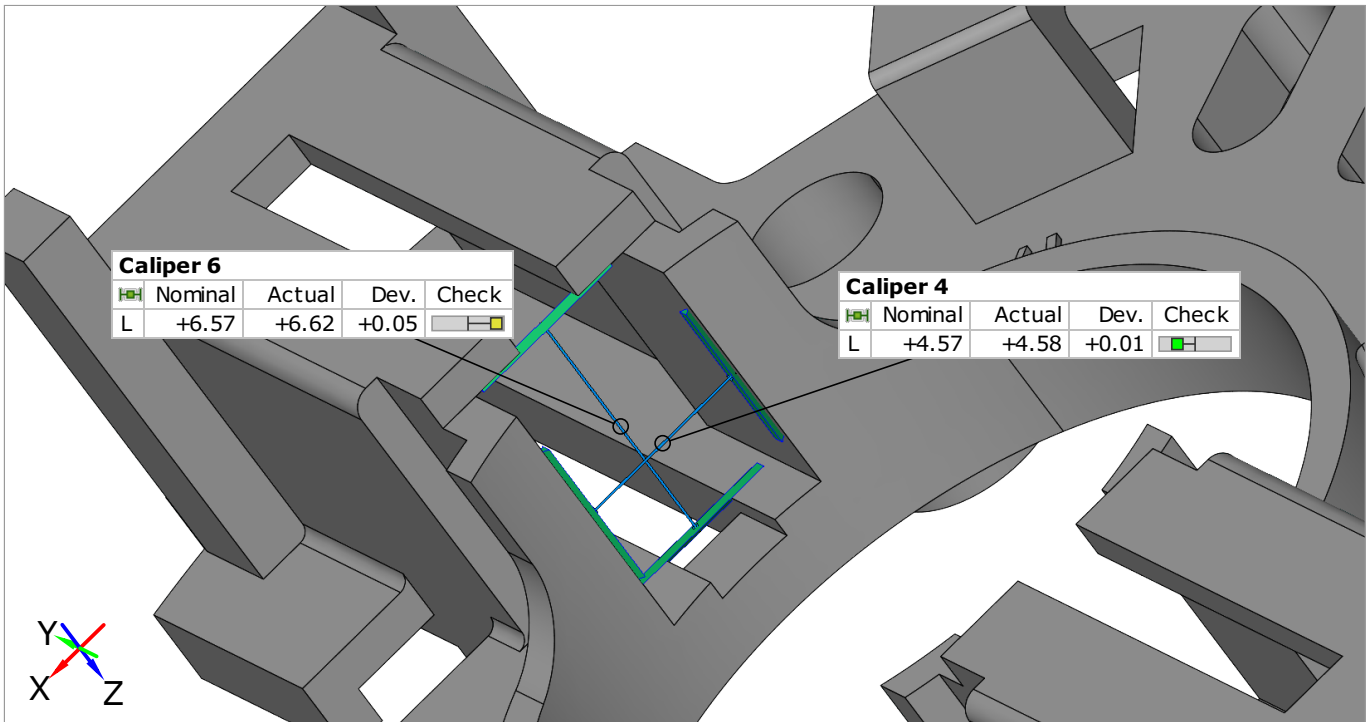

Caliper 6				
	Nominal	Actual	Dev.	Check
L	+6.57	+6.62	+0.05	<input type="checkbox"/>

Caliper 4				
	Nominal	Actual	Dev.	Check
L	+4.57	+4.58	+0.01	<input checked="" type="checkbox"/>

Prealignment 1

Length unit: mm

Element	Property	Nominal	Actual	Tol -	Tol +	Dev	Check	Out
Caliper 6	L	+6.57	+6.62	+0.00	+0.05	+0.05	<input type="checkbox"/>	
Caliper 5	L	+4.57	+4.59	+0.00	+0.05	+0.02	<input checked="" type="checkbox"/>	
Caliper 4	L	+4.57	+4.58	+0.00	+0.05	+0.01	<input checked="" type="checkbox"/>	
Caliper 3	L	+0.90	+0.85	-0.10	+0.00	-0.05	<input checked="" type="checkbox"/>	
Caliper 2	L	+0.70	+0.70	+0.00	+0.10	+0.00	<input type="checkbox"/>	
Caliper 1	L	+0.70	+0.73	+0.00	+0.10	+0.03	<input checked="" type="checkbox"/>	
Cylinder 2	D	+4.50	+4.29	-0.40	+0.00	-0.21	<input checked="" type="checkbox"/>	
Cylinder 1	D	+4.50	+4.31	-0.40	+0.00	-0.19	<input checked="" type="checkbox"/>	
Circle 1	D	+20.00	+20.10	+0.00	+0.30	+0.10	<input checked="" type="checkbox"/>	

Prealignment 1

Length unit: mm